

GoldRich PLANNERS & SURVEYORS LTD.

金潤規劃測量師行有限公司

Your Ref.: A/YL-KTS/1102

Our Ref.: P22068B/TL26187

19 May 2026

The Secretary
Town Planning Board
15/F., North Point Government Offices
333 Java Road, North Point, Hong Kong

By E-mail
tpbpd@pland.gov.hk

Dear Sir,

Submission of Further Information (FI)

Temporary Shop and Services (Retail Shop for Hardware Groceries and Construction Materials) with Ancillary Facilities for a Period of 5 Years in “Residential (Group D)” Zone, Lots 681 RP (Part), 682 RP (Part) and 683 RP (Part) in D.D. 106 and Adjoining Government Land, Yuen Long, New Territories (Application No. A/YL-KTS/1102)

We write to submit FI in response to departmental comment(s) conveyed by the Planning Department for the captioned application.

Yours faithfully,
For and on behalf of
Goldrich Planners & Surveyors Ltd.



Francis LAU

Encl.

c.c.

DPO/FS&YLE, PlanD (Attn.: [REDACTED])

Further Information for Planning Application No. A/YL-KTS/1102**Response-to-Comments****Comments from Drainage Services Department**

Contact person: Mr. Jeff Tse (Tel.: 3965 8921)

I.	Comments	Responses
1.	The proposed L-sharp pipe at the discharge point is not a typical connection to DSD's drainage facility, please review.	The discharge point has been reviewed. Please refer to Plan 5.1a.
2.	Referring to R-to-C, it is noted that no site formation/levelling works to be carried out under this application. Please state the above on the drainage plan (Plan 5.1a) for record.	Noted. Please refer to Plan 5.1a.
3.	As noted, the existing DSD's drainage facilities (SCH1026300, SGJ1038727 and SGJ1038728, etc.) will be maintained and not be affected due to the proposed development anytime. Please ask the applicant to indicate the nearby existing DSD's drainage facilities to the application site and will be maintained these drainage facilities anytime on the drainage plan for record.	The existing DSD's drainage facilities (SCH1026300, SGJ1038727 and SGJ1038728, etc.) have been indicated on plan. These existing DSD's drainage facilities (SCH1026300, SGJ1038727 and SGJ1038728, etc.) will be maintained and not be affected due to the proposed development. Please refer to Plan 5.1a.
4.	The development should neither obstruct overland flow and nor adversely affect existing natural streams, village drains, ditches and the adjacent areas, etc.	Noted.
5.	The applicant should resolve any conflict/disagreement with relevant lot owner(s) and seek permission from DLO/YL for laying new drains/channels and/or modifying/upgrading existing ones in other private lots or on Government Land, where required, outside the application site(s).	Noted.
6.	The applicant should submit form HBP1 to this Division for application of technical audit for any proposed connection to DSD's drainage facilities.	Noted.

- END -

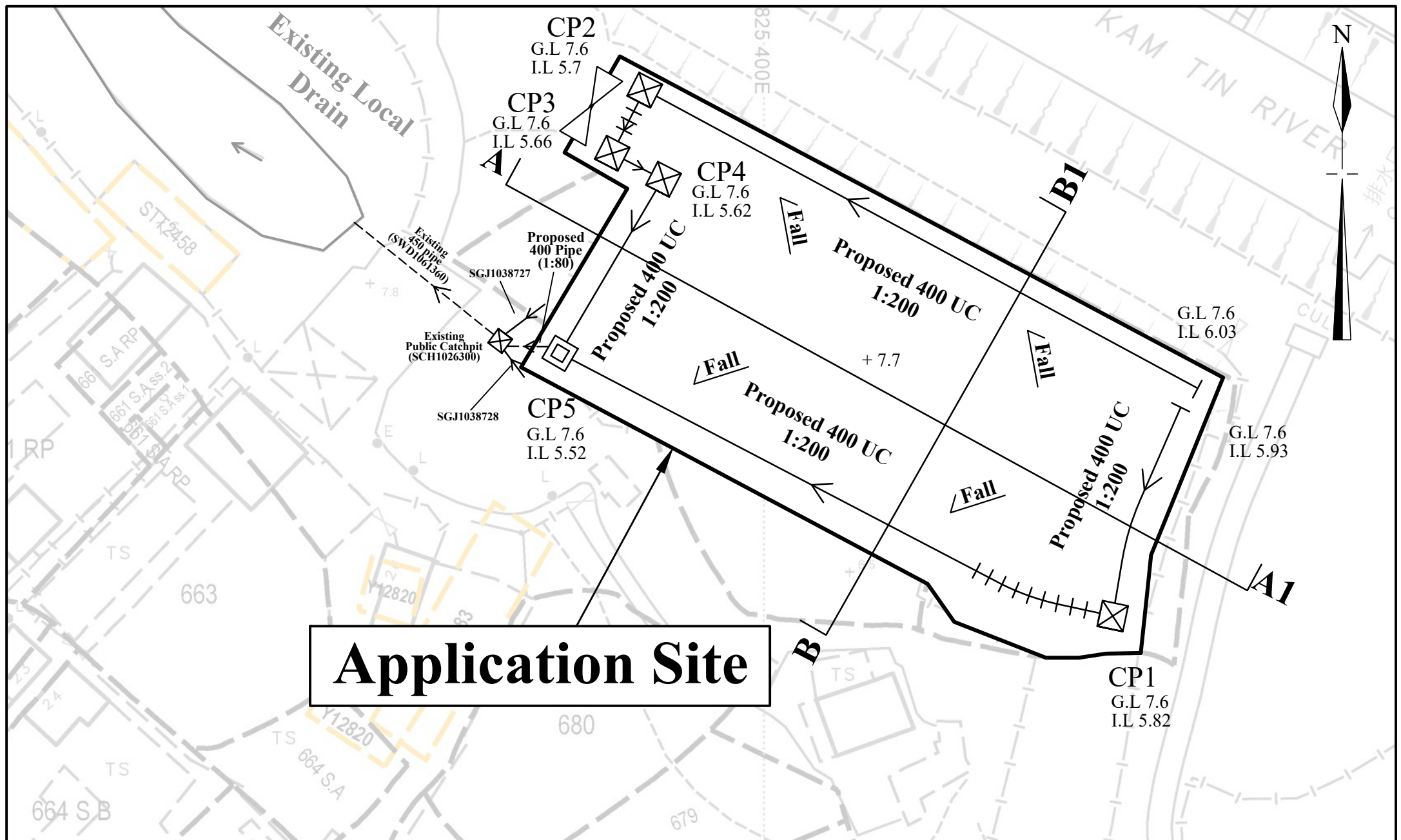

Legend:

- Vehicular Ingress/ Egress
- Catch-pit
- Catch-pit with trap
- U-Channel
- U-Channel with C.I. cover
- Pipe

Note: The existing DSD's drainage facilities (SCH1026300, SGJ1038727 and SGJ1038728, etc.) will be maintained and not to be affected due to the proposed development.

No site formation/levelling works to be carried out under this application

Site Area: 2,258m²

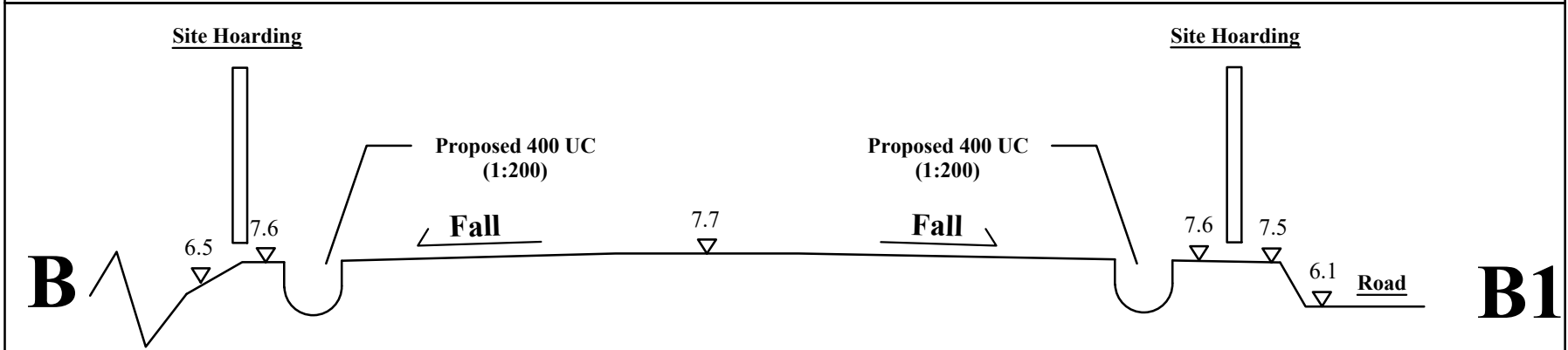
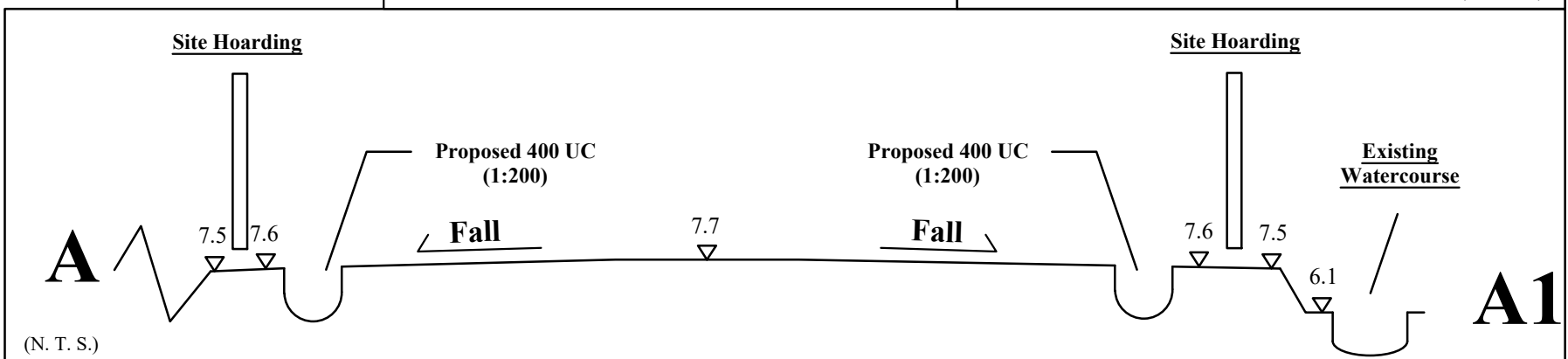
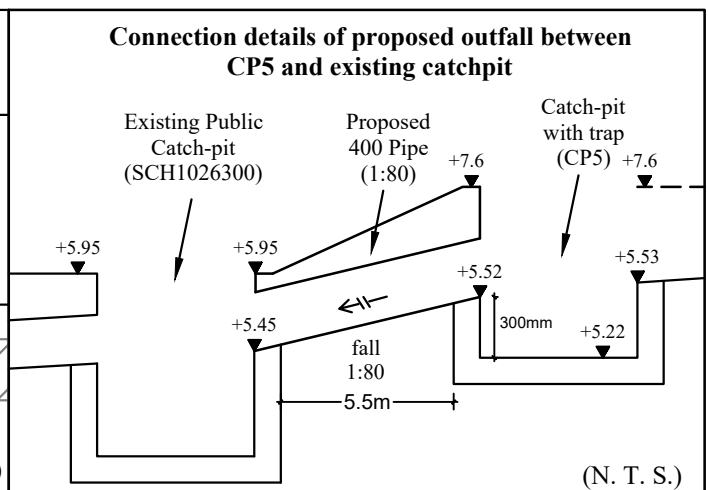
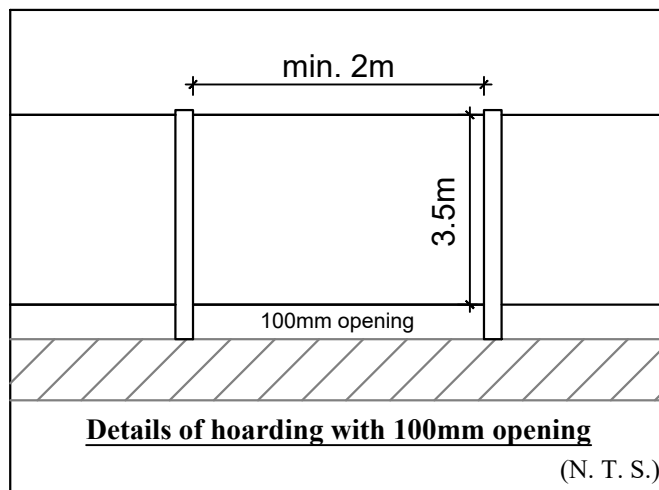

1:500 (A3)

March 2026

Drainage Proposal

Lots 681 RP(part), 682 RP(part) and 683 RP(part) in DD.106 and adjoining Government Land

Goldrich Planners & Surveyors Ltd.

Plan 5.1a
 (P 22068B)

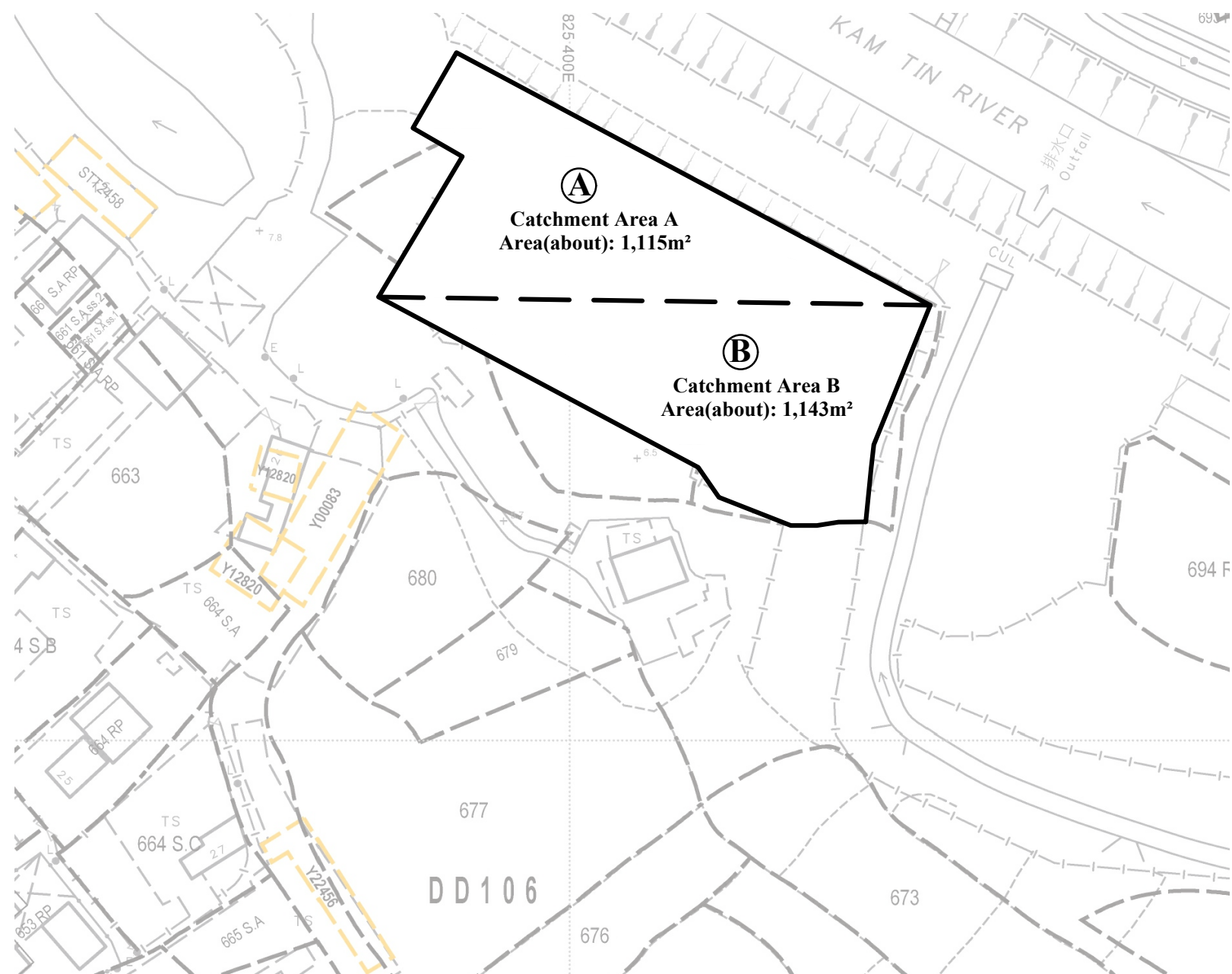

AREA OF CATCHMENT
(N.T.S)

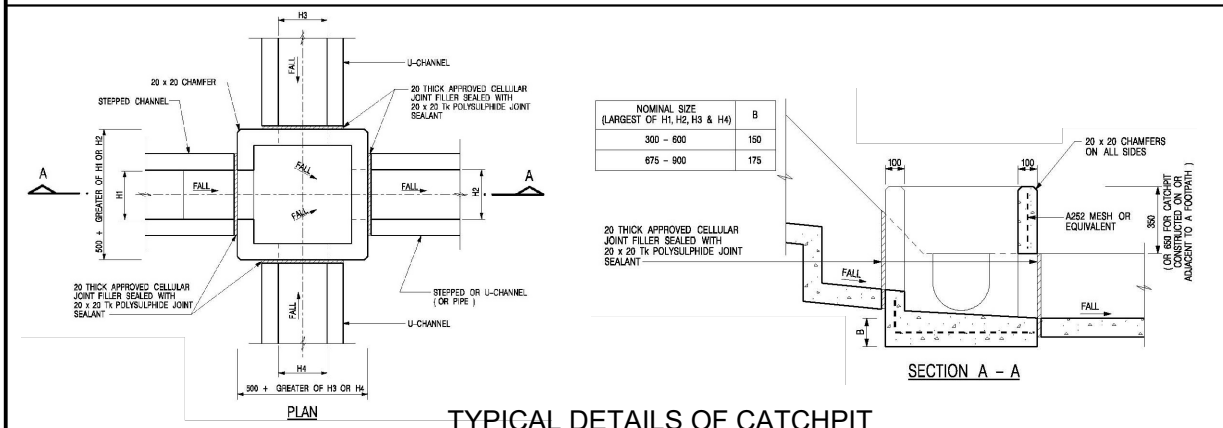

TYPICAL DETAILS OF CATCHPIT
(REFER TO CEDD'S STANDARD DWG. C2405/1)

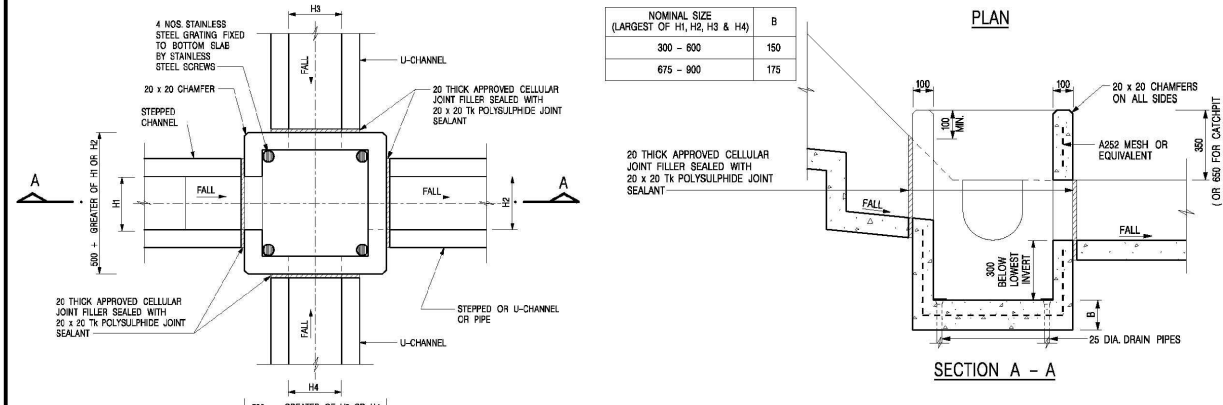

DETAILS OF CATCHPIT WITH TRAP
(REFER TO CEDD'S STANDARD DWG. C2406/1)

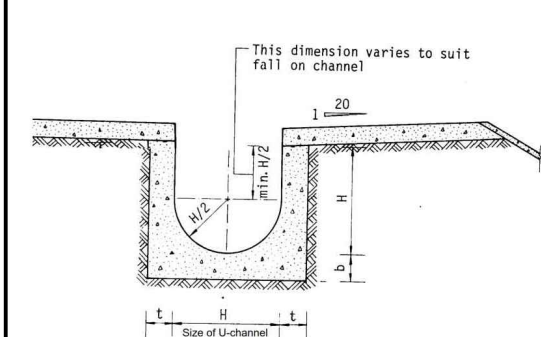

TYPICAL DETAILS OF U-CHANNEL
(Refer to DSD'S technical note to prepare a drainage submission)

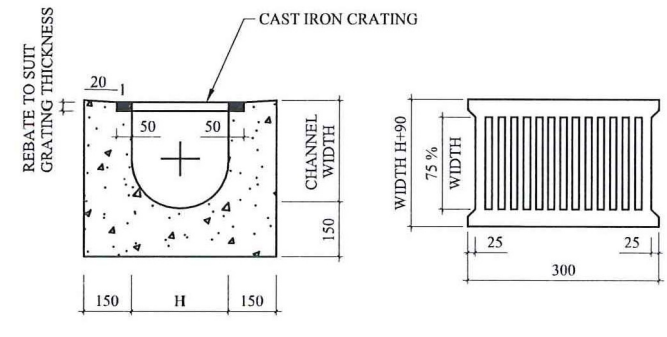

TYPICAL SECTION OF U-CHANNEL WITH COVER
(N.T.S.)

CAST IRON CRATING (HEAVY DUTY)

N.T.S

March 2026

Drainage Proposal

Lots 681 RP(part), 682 RP(part) and 683 RP(part) in DD.106 and adjoining Government Land

Goldrich Planners & Surveyors Ltd.

Plan 5.2a (P 22068B)

1 For Catchment Area A

Area, A = 1115 m²
 Average slope, H = 0.1 m per 100m
 Distance on the line of natural flow, L = 17 m

Time of concentration, $t_o = 0.14465L / (H^{0.2}A^{0.1}) = 0.14465 (17) / (0.1^{0.2} \times 1115^{0.1})$
 = 1.9 min

SDM 7.5.2 (d)

2 For Proposed UC in Catchment Area A

	From	To
Ground level (mPD)	7.60	7.60
Invert level (mPD)	6.03	5.52

Width of u-channel, w = 400 mm
 Length of u-channel, $L_c = 102$ m
 Depth of vertical part of u-channel, d = 1880 mm
 Gradient of u-channel, $S_f = (6.03-5.52)/102 = 0.005$

Cross-Section Area, $a = 0.5 \pi r^2 + w d = 0.5 \times 3.14 \times 200^2 + 400 \times 1880$
 = 0.815 m²
 Wetted Perimeter, $p = \pi r + 2 d = 3.14 \times 200 + 2 \times 1880$
 = 4.388 m
 Hydraulic radius, $R = a / p = 0.186$ m

SDM 8.2.1

3 Use Manning Equation for estimating velocity of stormwater

Take n = 0.016 for concrete lined channels:-
 Allowable velocity, $v = R^{1/6} \times (RS_f)^{1/2} / n = (0.186)^{1/6} \times (0.186 \times 0.005)^{1/2} / 0.016$
 = 1.44 m/s
 Time of flow, $t_f = 1.2$ min

SDM Table 13
 SDM Table 12

4 Use "Rational Method" for calculation of design flow

Design intensity, $i = a / (t_o + t_f + b)^c$
 = $505.5 / (1.9+1.2+3.29)^{0.355}$ for return period T = 50 years
 = 261

SDM 4.3.2
 Corrigendum 1/2024
 SDM Table 3a

Type of surface	Runoff Coefficient C	Catchment Area A (m ²)	C x A
Flat Glassland (heavy soil)	0.25	0.0	0.0
Concrete Paving	0.95	1115.0	1059.3
SUM =			1059.3

SDM 7.5.2 (b)

Upstream flow, $Q_u = 0$ m³/s

Design flow, $Q_d = 1.16 \times 0.278i \sum C_i A_i + Q_u$ where A_i is in km²
 = $1.16 \times 0.278 \times 261 \times 1059.25 / 1000000 + 0$
 = 0.089 m³/s

SDM 7.5.2 (a)
 Corrigendum 1/2022

Allowable flow, $Q_a = a \times v$
 = 0.815×1.44
 = 1.172 m³/s

> Q_d (O.K.)

Reference was made to Stormwater Drainage Manual (SDM) by DSD

Scale: NA

Hydraulic Calculation

Goldrich Planners &
 Surveyors Ltd.

May 2026

Lots 681 RP (Part), 682 RP (Part) and 683 RP (Part) in D.D. 106 and
 Adjoining Government Land, Yuen Long, New Territories

Page 1
 (P22068B)

1 For Catchment Area B

Area, A = 1143 m²
 Average slope, H = 0.1 m per 100m
 Distance on the line of natural flow, L = 16 m

Time of concentration, $t_0 = 0.14465L / (H^{0.2}A^{0.1}) = 0.14465 (16) / (0.1^{0.2} \times 1143^{0.1})$
 = 1.8 min

SDM 7.5.2 (d)

2 For Proposed UC in Catchment Area B

	From	To
Ground level (mPD)	7.60	7.60
Invert level (mPD)	5.93	5.52

Width of u-channel, w = 400 mm
 Length of u-channel, $L_c = 82$ m
 Depth of vertical part of u-channel, d = 1880 mm
 Gradient of u-channel, $S_f = (5.93-5.52)/82 = 0.005$

Cross-Section Area, $a = 0.5 \pi r^2 + w d = 0.5 \times 3.14 \times 200^2 + 400 \times 1880$
 = 0.815 m²
 Wetted Perimeter, $p = \pi r + 2 d = 3.14 \times 200 + 2 \times 1880$
 = 4.388 m
 Hydraulic radius, $R = a / p = 0.186$ m

SDM 8.2.1

3 Use Manning Equation for estimating velocity of stormwater

Take n = 0.016 for concrete lined channels:-
 Allowable velocity, $v = R^{1/6} \times (RS_f)^{1/2} / n = (0.186)^{1/6} \times (0.186 \times 0.005)^{1/2} / 0.016$
 = 1.44 m/s
 Time of flow, $t_f = 1.0$ min

SDM Table 13
 SDM Table 12

4 Use "Rational Method" for calculation of design flow

Design intensity, $i = a / (t_0 + t_f + b)^c$
 = $505.5 / (1.8+1+3.29)^{0.355}$ for return period T = 50 years
 = 267

SDM 4.3.2
 Corrigendum 1/2024
 SDM Table 3a

Type of surface	Runoff Coefficient C	Catchment Area A (m ²)	C x A
Flat Glassland(heavy soil)	0.25	0.0	0.0
Concrete Paving	0.95	1143.0	1085.9
SUM =			1085.9

SDM 7.5.2 (b)

Upstream flow, $Q_u = 0$ m³/s

Design flow, $Q_d = 1.16 \times 0.278i \sum C_f A_i + Q_u$ where A_i is in km²
 = $1.16 \times 0.278 \times 267 \times 1085.85 / 1000000 + 0$
 = 0.093 m³/s

SDM 7.5.2 (a)
 Corrigendum 1/2022

Allowable flow, $Q_a = a \times v$
 = 0.815×1.44
 = 1.172 m³/s

> Q_d (O.K.)

Reference was made to Stormwater Drainage Manual (SDM) by DSD

Scale: NA

Hydraulic Calculation

Goldrich Planners &
 Surveyors Ltd.

May 2026

Lots 681 RP (Part), 682 RP (Part) and 683 RP (Part) in D.D. 106 and
 Adjoining Government Land, Yuen Long, New Territories

Page 2
 (P22068B)

1 For Connection between CP5 to Existing Public Catchpit

Area, A = 0 m²
 Average slope, H = 0.1 m per 100m
 Distance on the line of natural flow, L = 0 m

Time of concentration, t₀ = 0.14465L / (H^{0.2}A^{0.1}) = 0.14465 (0) / (0.1^{0.2}*0^{0.1})
 = 0.0 min

Ref.

SDM 7.5.2 (d)

2 For Pipe after CP5

Size(Diameter) w = 400 mm
 Length of Pipe = 5.5 m
 Design the pipe to 9/10 full bore capacity, then
 Area of ventilated portion = 0.1 of pipe area
 $\frac{1}{2} r^2 \theta - \frac{1}{2} r^2 \sin(\theta) = 0.1 \pi r^2$
 $\theta - \sin(\theta) = 0.2 \pi$
 $\theta = 1.63 \text{ rad} = 93.4^\circ$ (By trial and error)

Area A = 0.9 πr^2
 = 0.9 x 3.14 x 400²
 = 0.452 m²

Wetted Perimeter P = 2 $\pi r - r \theta = 1861 \text{ mm}$
 Hydraulic radius R = $\frac{A}{P} = 242.9 \text{ mm}$

SDM 8.2.1

3 Use Manning Equation for estimating velocity of stormwater

Fall S = 1: 80
 Take n = 0.016 for concrete lined channels:-
 Allowable velocity, v = $R^{1/6} \times (RS)^{1/2} / n = (242.9)^{1/6} * (242.9/80)^{1/2} / 0.016$
 = 2.61 m/s
 Time of flow, t_f = 0.04 min

SDM Table 13
 SDM Table 12

4 Use "Rational Method" for calculation of design flow

Design intensity, i = a / (t₀ + t_f + b)^c
 = 505.5 / (0.0+0.04+3.29)^{0.355} for return period T = 50 years
 = 330

SDM 4.3.2
 Corrigendum 1/2024
 SDM Table 3a

Type of surface	Runoff Coefficient C	Catchment Area A (m ²)	C x A
Flat Grassland (heavy soil)	0.25	0.0	0.0
Concrete Paving	0.95	0.0	0.0
Macadam Roadways	0.425	0.0	0.0
Wooded Areas	0.105	0.0	0.0
SUM =			0.0

SDM 7.5.2 (b)

Upstream flow, Q_u = 0.182 m³/s

Design flow, Q_d = 0.278i $\sum C_i A_i$ + Q_u where A_i is in km²
 = 1.16 x 0.278 x 330 x 0 / 1000000 + 0.182
 = 0.182 m³/s

SDM 7.5.2 (a)
 Corrigendum 1/2022

Allowable flow, Q_a = a x v
 = 0.3974 x 1.35
 = 1.179 m³/s

> Q_d (O.K.)

Reference was made to Stormwater Drainage Manual (SDM) by DSD

Scale: NA

Hydraulic Calculation

Goldrich Planners &
 Surveyors Ltd.

May 2026

Lots 681 RP (Part), 682 RP (Part) and 683 RP (Part) in D.D. 106 and
 Adjoining Government Land, Yuen Long, New Territories

Page 3
 (P22068B)

1 For Connection between Existing Public Catchpit (SCH1026300) to Existing Local Drain

Area, A = 0 m²
 Average slope, H = 0.1 m per 100m
 Distance on the line of natural flow, L = 0 m

Time of concentration, t₀ = 0.14465L / (H^{0.2}A^{0.1}) = 0.14465 (0) / (0.1^{0.2} × 0^{0.1})
 = 0.0 min

Ref.

SDM 7.5.2 (d)

2 For Existing 450 pipe (SWD1061360) before Existing Local Drain

Size(Diameter) w = 450 mm
 Length of Pipe = 21 m
 Design the pipe to 9/10 full bore capacity, then
 Area of ventilated portion = 0.1 of pipe area
 $\frac{1}{2} r^2 \theta - \frac{1}{2} r^2 \sin(\theta) = 0.1 \pi r^2$
 $\theta - \sin(\theta) = 0.2 \pi$
 $\theta = 1.63 \text{ rad} = 93.4^\circ$ (By trial and error)

Area A = 0.9 π r²
 = 0.9 × 3.14 × 450²
 = 0.572 m²

Wetted Perimeter P = 2 π r - r θ = 2094 mm
 Hydraulic radius R = A/P = 273.3 mm

SDM 8.2.1

3 Use Manning Equation for estimating velocity of stormwater

Fall S = 1: 90
 Take n = 0.016 for concrete lined channels:-
 Allowable velocity, v = R^{1/6} × (RS_n)^{1/2} / n = (273.3)^{1/6} × (273.3/90)^{1/2} / 0.016
 = 2.46 m/s
 Time of flow, t_f = 0.14 min

SDM Table 13
 SDM Table 12

4 Use "Rational Method" for calculation of design flow

Design intensity, i = a / (t₀ + t_f + b)^c
 = 505.5 / (0.0 + 0.14 + 3.29)^{0.355} for return period T = 50 years
 = 326

SDM 4.3.2
 Corrigendum 1/2024
 SDM Table 3a

Type of surface	Runoff Coefficient C	Catchment Area A (m ²)	C x A
Flat Grassland (heavy soil)	0.25	0.0	0.0
Concrete Paving	0.95	0.0	0.0
Macadam Roadways	0.425	0.0	0.0
Wooded Areas	0.105	0.0	0.0
SUM =			0.0

SDM 7.5.2 (b)

Upstream flow, Q_u = 0.182 m³/s

Design flow, Q_d = 0.278i Σ C_iA_i + Q_u where A_i is in km²
 = 1.16 × 0.278 × 326 × 0 / 1000000 + 0.182
 = 0.182 m³/s

SDM 7.5.2 (a)
 Corrigendum 1/2022

Allowable flow, Q_a = a × v
 = 0.3974 × 1.35
 = 1.407 m³/s

> Q_d (O.K.)

Reference was made to Stormwater Drainage Manual (SDM) by DSD

Scale: NA

Hydraulic Calculation

Goldrich Planners &
 Surveyors Ltd.

May 2026

Lots 681 RP (Part), 682 RP (Part) and 683 RP (Part) in D.D. 106 and
 Adjoining Government Land, Yuen Long, New Territories

Page 4
 (P22068B)